

Busch Vacuum Pumps and Systems



Busch Vacuum Pumps and Systems



Busch Manufacturing Plant – Virginia Beach, Virginia



At Busch, we are dedicated to serving our customers needs.



Busch Manufacturing Plant – Germany



Busch Manufacturing Plant – Switzerland

Vacuum Pump Selection Guide

General Industry	R 5 Rotary Vane	Mink Rotary Claw	Merlin Rotary Claw	COBRA Rotary Screw	Seco Rotary Vane	EXT Rotary Vane
Beverage Industry		■				
Boat Industry	■	■				
Brickmaking and Ceramics	■	■				
Chemical				■		
Die Casting	■	■		■		
Environmental Technology	■	■				
Food Packaging and Processing	■	■				
Medical and Hospitals	■	■				
Metallurgy	■	■		■		
Packaging	■	■			■	
Pharmaceutical Industry	■	■		■		
Plastics Industry	■	■		■		■
Pneumatic Conveying	■	■				
Printing Circuit Board Testing	■	■			■	
Printing Industry	■	■	■		■	
Research and Laboratory	■	■		■		
Textile Industry	■	■			■	
Thermoforming	■	■			■	
Transport and Handling	■	■			■	
Vacuum Furnace Industry	■			■		
Water and Wastewater	■	■				
Wood Working	■	■			■	
Consult factory for your specific application						

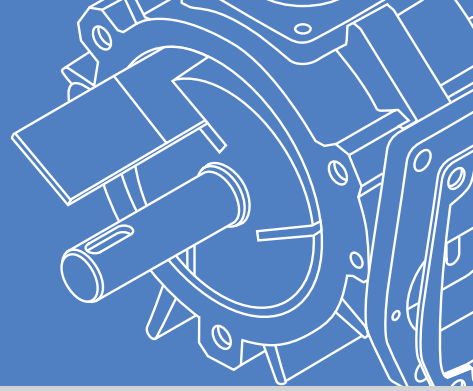

Busch pumps are manufactured from the finest materials with stringent quality controls.



A large staff of engineers with extensive experience in vacuum design will help determine the right system to meet your requirements.

Dr. Karl Busch designed the first Busch vacuum pump in 1963 for the meat packaging industry. From that beginning, Busch has grown to become a worldwide leader in vacuum technology with four manufacturing plants and 40 companies worldwide.

Busch prides itself in being a problem-solving company that provides solutions to vacuum design challenges all over the world. Busch designs and manufactures a wide range of high performance vacuum pumps and systems that are used in many industries. Busch, Inc. is an ISO 9001-2000 registered company, committed to quality vacuum products, customer satisfaction, and prompt after-sales service.

The U.S. facility in Virginia Beach is headquarters for engineering, manufacturing, sales, service, and warehousing. It also serves a network of distributors, representatives, and service centers located throughout the United States, Mexico, and Puerto Rico.



Nationwide sales, distribution, and service centers. Includes Puerto Rico.

Huckepack Rotary Vane	Samos Regenerative Blower	Panda Rotary Lobe Booster	Dolphin Liquid Ring
			■
	■		
■			■
■			
	■		
	■	■	
	■	■	
	■		
■			
■			
	■		■
	■		
	■		
■			
	■		
	■		
	■		■
	■		■



R 5 Vacuum Pumps

Description

The modular designed Busch R 5 rotary vane vacuum pumps are single stage, air-cooled, and direct driven. This oil-recirculating design is one of the simplest and most reliable vacuum pumps available on the world market.

These rugged vacuum pumps are used in a variety of industries such as packaging and food processing, rubber molding, thermoforming, printed circuit board testing, hospitals, laboratories, robotics, vacuum lamination, woodworking, printing, and many others.



R 5 0255

R 5 Operating Principle

Rotation of the vacuum pump rotor traps entering vapor between rotor vane segments where it is compressed, then discharged into the exhaust box. Exhaust vapors pass through several stages of internal oil and mist eliminators. Oil is then returned to the oil reservoir.

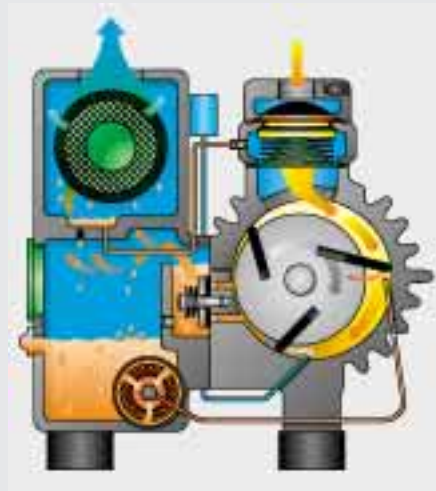

Technical Data

R 5 Model		0006	0010	0012	0016	0021	0025	0040	0063	0100	0101
Nominal pumping speed	ACFM	3.9	6	7	8.6	14	18	26	36	56	71
Free air displacement	CFM	4.2	7.1	8.5	11.2	15	20	28	41	63	77
Sound rating	dB(A)	62	69	68	70	72	70	70	70	71	71
Motor size for 3 phase	HP	1/2	3/4	3/4	3/4	1	1 1/2	2	3	5	5
Motor size for 1 phase	HP	1/2	1	3/4	1	1 1/4	1 1/2	2	3	5	5
Motor speed	RPM	3550	1750	1750	1750	3550	1750	1750	1750	1750	1750
Approx. oil capacity	Qt*	0.1	0.5	0.5	0.5	0.5	1.4	1.4	2.5	2.7	2.7
End vacuum – RC	Torr	NA	15	15	15	15	15	15	15	15	15
End vacuum – RA ¹	Torr	2**	0.5	2**	0.5	2**	0.5	0.5	0.5	0.5	0.5
Approx. weight	Lbs	28	49	42	60	42	106	120	172	198	198

1. Models 0165-0630 are continuous duty. Consult factory for special applications.

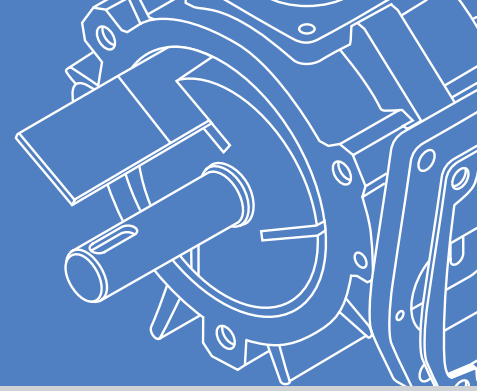

Performance Data (Based on 60 cycle motor, with gas ballast closed)

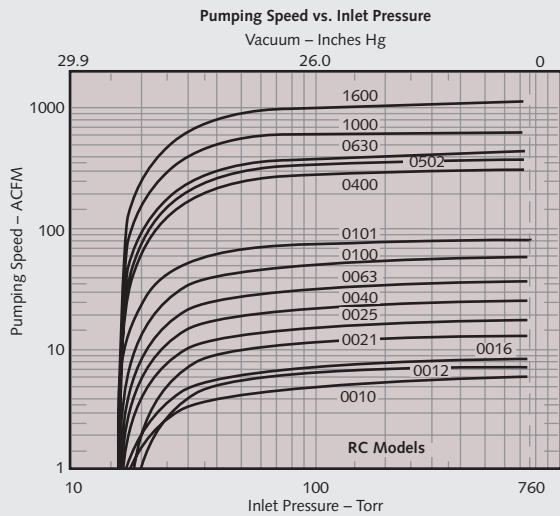
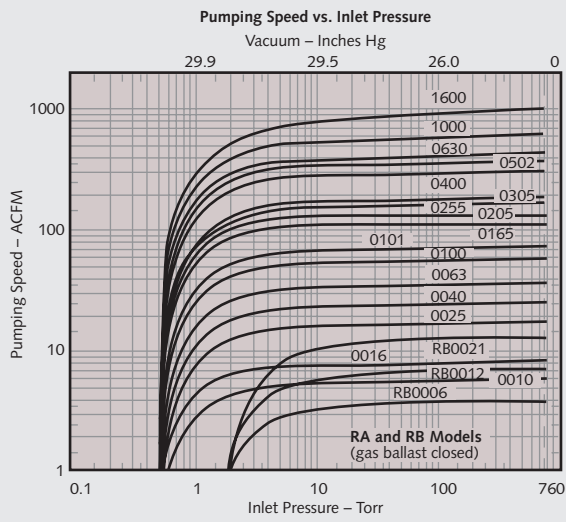

Busch Advantages

- Compact, simple design for easy installation and low maintenance
- Air-cooled, requiring no water
- Direct drive, eliminating belts and gears to loosen or wear
- Quiet operation
- Water-cooled versions available
- Maintenance kits available

0165	0205	0255	0305	0400	0502	0630	1000	1600
115	130	170	196	305	375	455	670	1030
117	141	180	212	330	413	490	704	1130
79	79	81	81	83	84	85	85	86
7.5	7.5	10	12	15	20	25	40	50
NA	NA	NA	NA	NA	NA	NA	NA	NA
1750	1750	1750	1750	1150	1150	1150	1150	1150
7	7	7	7	14	16	16	42	44
NA	NA	NA	NA	15	15	15	15	15
0.5	0.5	0.5	0.5	0.5	0.5	0.5	0.5	0.5
416	435	460	575	1152	1316	1525	2151	2833

* We recommend Busch R-530 vacuum pump oil for most applications; Busch R-580 vacuum pump oil for models 0006 and 0021; and Busch R-590 for severe applications.

** RB version for Models 0006, 0012, and 0021.



Mink Pressure or Vacuum Pumps

Description

The Busch Mink is a rotary claw-type, positive displacement, dry vacuum pump designed for either pressure or vacuum applications. The Mink is available as a single-stage or two-stage vacuum pump. Vacuum or pressure is produced by two non-contacting rotors in an oil-free pumping chamber. The dry, non-contacting design makes the Mink ideal for pneumatic conveying, printing, soil remediation, and any application where dust particles may be present. Wearing parts are separated from the pumping chamber which leads to a longer pump life with low maintenance.



Mink MM 1252 AV

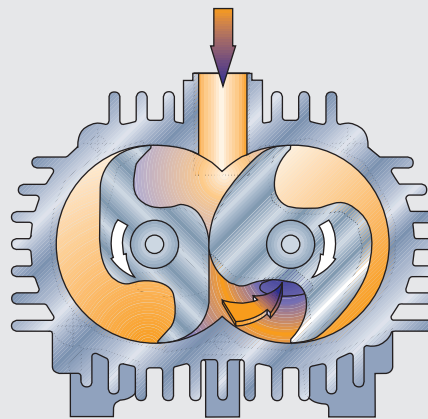

Mink Operating Principle

Two non-contacting claws trap a volume of air at the inlet and convey it to the exhaust where it is compressed and discharged.

Technical Data

Mink MI Model (Vacuum)		1124 BV	1122 BV	1354 BV	1504 BV	1352 BV	1502 BV	2124 BV*	2122 BV*
Nominal pumping speed	ACFM	38	85	108	160	216	325	38	85
Free air displacement	CFM	50	100	125	188	250	376	50	100
End vacuum	Torr	75	75	173	173	173	165	15	15
Motor size	HP	3.0	5.0	5.0	7.5	10	15	3	7.5
Motor speed	RPM	1800	3600	1800	1800	3600	3600	1800	3600
Inlet pipe connection	Inches	1 ¹ / ₄	1 ¹ / ₄	2	2	2	3	1 ¹ / ₄	1 ¹ / ₄
Discharge pipe connection	Inches	1 ¹ / ₂	1 ¹ / ₂	2	2	2	3	1 ¹ / ₂	1 ¹ / ₂
Sound rating	dBA	78	84	81	81	85	85	77	84
Approx. weight	Lbs	231	253	680	760	775	950	325	352
Mink MI Model (Pressure)		1124 BP	1122 BP	1354 BP	1504 BP	1352 BP	1502 BP		
Nominal pumping speed	SCFM	38	85	108	160	216	325		
Free air displacement	CFM	50	100	125	188	250	376		
Maximum pressure	psig	29.4	29.4	29.4	29.4	29.4	29.4		
Motor size	HP	7.5	15	15	20	30	40		
Motor speed	RPM	1800	3600	1800	1800	3600	3600		
Discharge pipe connection	Inches	1 ¹ / ₄	1 ¹ / ₄	2	2	2	3		
Sound rating	dBA	76	84	85	85	86	87		
Approx. weight	Lbs	243	297	1025	1075	1195	1350		
		* Two stage models							

Performance Data Model MI (Based on 60 cycle motor)

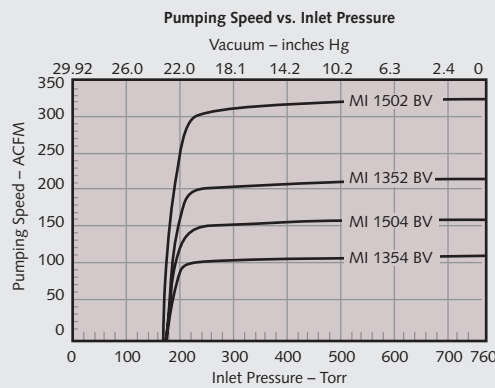
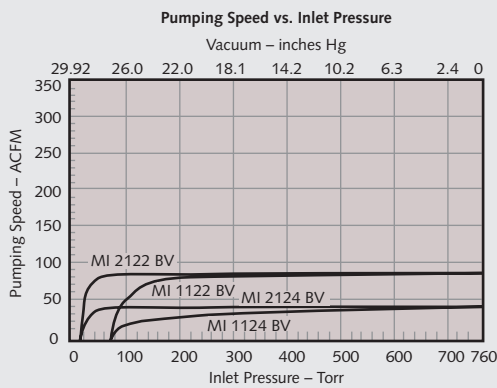
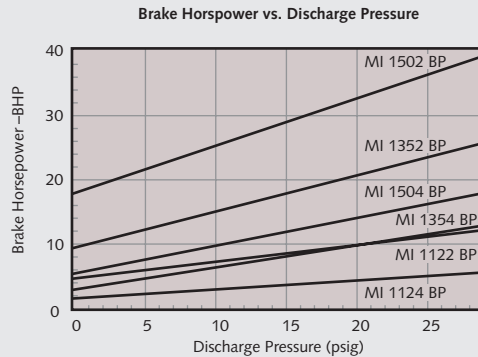
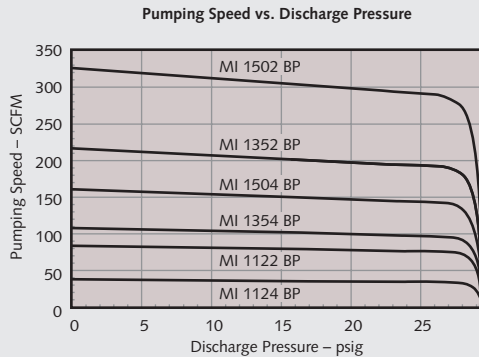
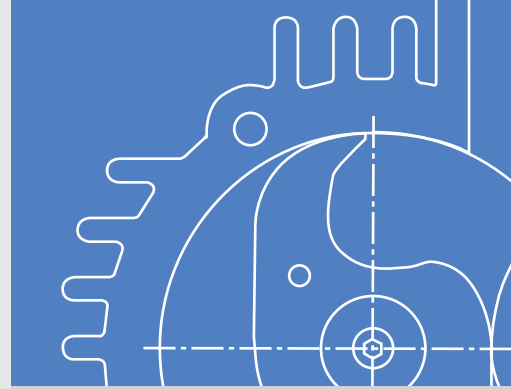

Technical Data

Mink MM Model (Vacuum)		1104 AV	1144 AV	1102 AV	1142 AV
Nominal pumping speed	ACFM	40	53	74	97
Free air displacement	CFM	43	58	86	116
End vacuum continuous duty	Torr	37.5	37.5	37.5	37.5
End vacuum intermittent duty	Torr	N/A	N/A	N/A	N/A
Motor size	kW (HP)	1.5 (2.0)	2.2 (3.0)	3.0 (4.0)	4.0 (5.4)
Motor speed	RPM	1800	1800	3600	3600
Sound rating	dBA	75	75	80	80
Approx. weight	Lbs	320	330	330	352
Mink MM Model (Vacuum)		1324 AV	1202 AV	1252 AV	1322 AV
Nominal pumping speed	ACFM	106	135	165	200
Free air displacement	CFM	109	142	177	218
End vacuum continuous duty	Torr	37.5	75	75	112.5
End vacuum intermittent duty	Torr	37.5	37.5	37.5	37.5
Motor size	kW (HP)	3.6 (4.8)	4.8 (6.4)	5.5 (7.4)	6.5 (8.7)
Motor speed	RPM	1800	3600	3600	3600
Sound rating	dBA	74	79	79	82
Approx. weight	Lbs	513	519	528	532

Busch Advantages

- Non-contacting design
- Dry (oil-free) pumping chamber
- Air-cooled
- Low maintenance – no wear in pumping chamber
- Simple, modular construction
- Suitable for variable speed applications
- Discharge silencers on vacuum models. Inlet silencers on pressure models
- Frame rails on models MI 1354-1502 BV/BP
- Suitable for dusty environments
- Integral relief valve (where necessary)
- Inlet filters on pressure models



Performance Data Model MM (Based on 60 cycle motor)

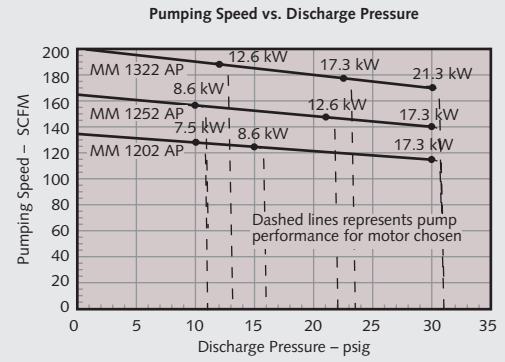
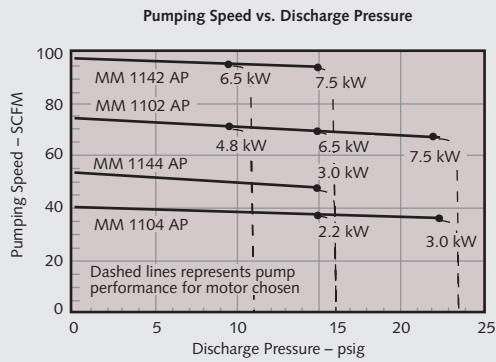
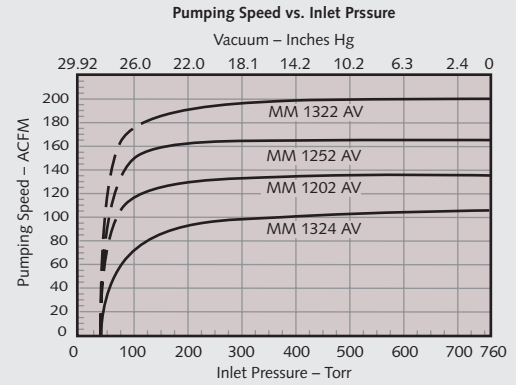
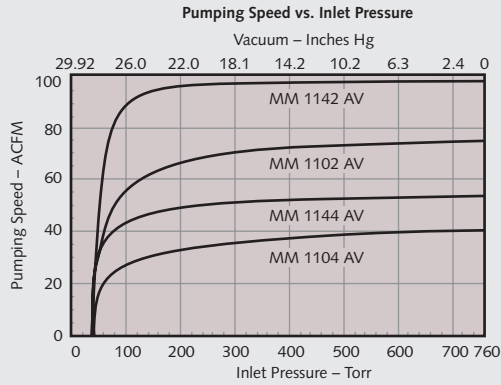

Technical Data

Mink MM Model (Pressure)		1104 AP	1144 AP	1102 AP	1142 AP	1202 AP	1252 AP	1322 AP
Nominal pumping speed	SCFM	40	53	74	97	135	165	200
Free air displacement	CFM	43	58	86	116	142	177	218
Motor size ¹	kW (HP)	2.2 (3.0)	3.0 (4.0)	4.8 (6.5)	6.5 (8.7)	7.5 (10.0)	8.6 (11.5)	12.6 (16.9)
Motor rotational speed	RPM	1800	1800	3600	3600	3600	3600	3600
Maximum pressure	psig	16.0	16	11	11	11	11	13
Relief valve cracking press.	psig	15	15	10	10	15	10	12
Sound level	dB(A)	82	83	86	87	82	83	85
Approximate weight	Lbs	323	337	350	367	519	528	550
1. Larger motor sizes are available that offer the same pumping speeds with higher maximum pressures. Contact Busch for individual product data sheets.								

Merlin Pressure and Vacuum Pumps

Description

The Merlin is a rotary, non-contacting, claw-type, combination pump that provides both pressure and vacuum with independent, completely oil-free pumping chambers. The Merlin is welcomed by professional printers because of its extreme tolerance of paper dust along with its low cost of ownership.



Merlin ME 3048 D

Low Ownership Cost

- Maintenance – with non contacting claw-type rotors, there are no vanes to wear or replace, so there is no downtime.
- Small motor – because the rotors are friction free, the Merlin uses a smaller motor which consumes less energy than other types of pumps. Even a single Merlin pump can save almost \$2,000 a year in electrical costs.

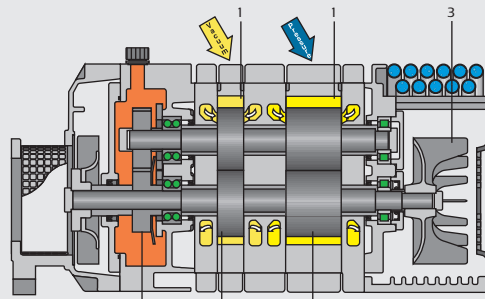

1. Compression Chamber
2. Rotary Claw
3. Fan
4. Gear

Merlin Operating Principle

Two non-contacting claws trap a volume of air at the inlet and convey it to the exhaust where it is compressed and discharged.

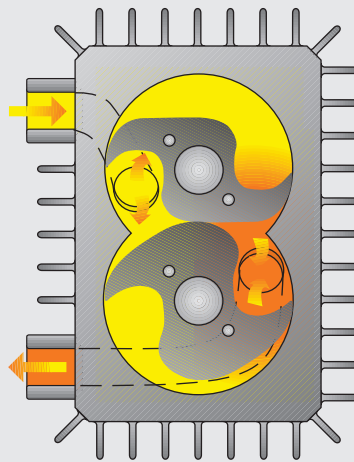

Technical Data

Merlin ME Model		2048 D			3048 D	
Max. vacuum (1 st stage)	"Hg	18	18	18	18	18
Max. vacuum (2 nd stage)	"Hg	N/A	N/A	N/A	15	15
Maximum pressure	psig	10	15	10	10	10
Motor size	kW	2.6	3.6	4	3.6	5.5
Sound level	dBA	76	76	80	77	80

Technical data on pump models varies depending on motor speed and pressure relief valve. Consult factory for details.

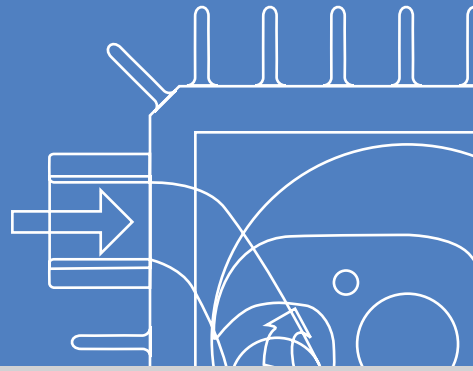

Busch Advantages

- Non-wearing, non-contacting, double claw-type design
- Dry pumping chambers
- Separate pressure and vacuum chambers
- Air-cooled
- Compact
- Simple, modular construction
- Cooling coils for blast air
- Long life, low maintenance
- Quiet



COBRA Vacuum Pumps

Description

The COBRA single stage, direct driven, dry vacuum pumps, with their unique rotary screws, are designed for difficult applications in the pharmaceutical and chemical processing industries. They require no intercoolers and offer greater efficiency and easier maintenance than other types of dry vacuum pumps. The COBRA N series B version uses a unique, monoblock, continuously variable pitch screw design. The variable pitch design operates more efficiently, has a higher CFM to horsepower ratio, and lower operating temperatures than traditional dry screw vacuum pumps. The COBRA N series A and AC versions use a constant pitch screw design. The COBRA N series vacuum pumps are available as direct cooled or closed loop air-cooled models, while the COBRA AC series is only available as direct cooled models. For higher pumping speeds and lower ultimate pressures, Busch offers many custom designed vacuum systems.



COBRA N 0200 B
Direct Cooled Model



COBRA N 0250 A
Air Cooled Model

COBRA Operating Principle

Entering gases are trapped between flights of the screws and moved axially down a short straight path to the exhaust where they are discharged.

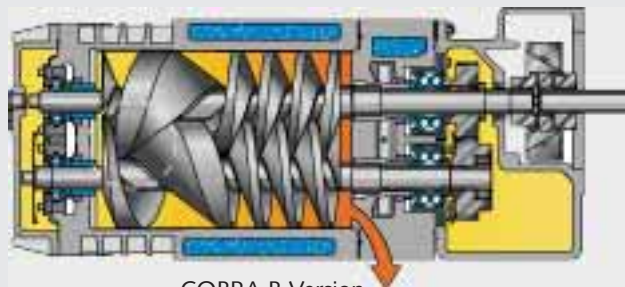

COBRA B Version

Technical Data

COBRA N Model		0100 B	0200 B	0300 B	0070 A	0160 A	0250 A
Nominal pumping speed	ACFM	82	160	225	50	115	180
Free air displacement	CFM	90	177	241	58	135	210
End vacuum	Torr	.0075	.0075	.0075	.075	.075	.075
Motor size	HP	5	10	15	5	7.5	15
Motor speed	RPM	3600	3600	3600	3600	3600	3600
Sound rating	dBA	75	78	80	75	82	82
Oil sump capacity	Qts	2	2	2	2	2	2
Average water usage rate	GPM	1	1	1	1	1	1
Approx. weight	Lbs	517	638	693	1000	1400	1600

Performance Data (Based on 60 cycle motor)

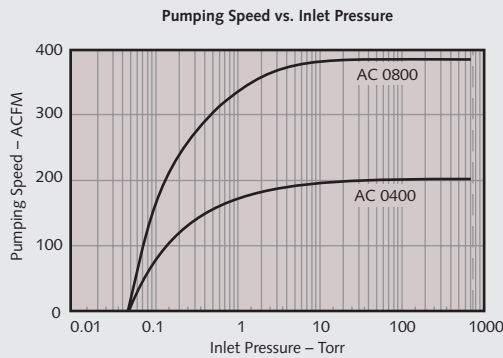
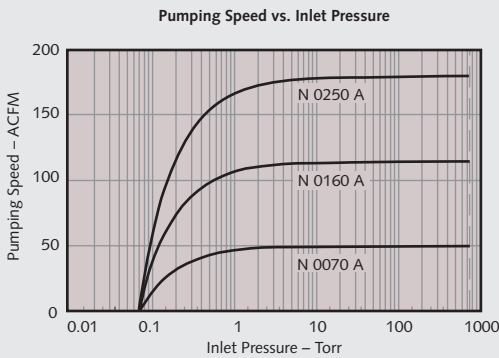
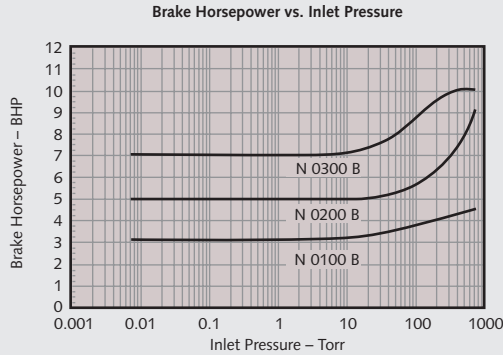
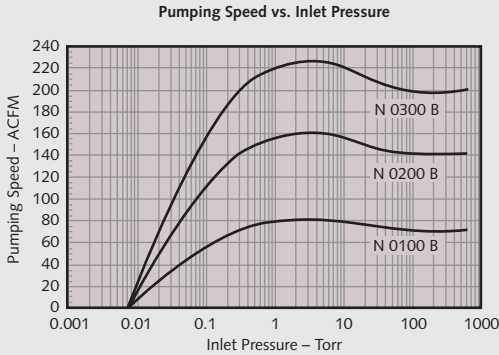

Technical Data

COBRA AC Model		0400	0800
Nominal pumping speed	ACFM	200	385
Free air displacement	CFM	262	495
End vacuum	Torr	.05	.05
Motor size	HP	20	40
Motor speed	RPM	3600	3600
Sound rating	dB(A)	82	85
Oil sump capacity	Qts	3.2	3.7
Average water usage rate	GPM	2	3.2
Approx. weight	Lbs	1700	2400

Busch Advantages

- Oil-free operation
- Solid construction "monoblock" screws
- Continuously variable pitch design
- No balancing ports in screws
- Single stage
- Non-contacting design
- Protective coating on internal parts
- Straight, short flow path for quick discharge
- Small footprint
- Low vibration and noise levels
- Protective instrumentation
- Mechanical shaft seals
- Low coolant requirements



Huckepack HO Vacuum Pumps

Description

The Busch Huckepack HO vacuum pump is a two-stage, once-through-sealing, rotary vane design. The Mark 4 design allows engineers the flexibility and performance they need for their particular process, including the choice of several sealing fluids with different vapor pressures.

Features

- Coolant temperature control system
- Graphite PTFE exhaust and bypass valves
- Adjustable sealant metering pump
- Grease-lubricated bearings
- Sealant reservoir and optional flushing tank for different fluids during flushing cycle
- Protective instrumentation
- Wide selection of sealing fluids



Huckepack HO Mark 4
Radiator Cooled

Huckepack Operating Principle

A small amount of sealant from an external reservoir is continuously metered into the pump cavity for vacuum sealing and lubrication. The sealant washes the internal surfaces, preventing contaminate buildup. It is then discharged with the process vapor into the exhaust system, where it is separated and removed.

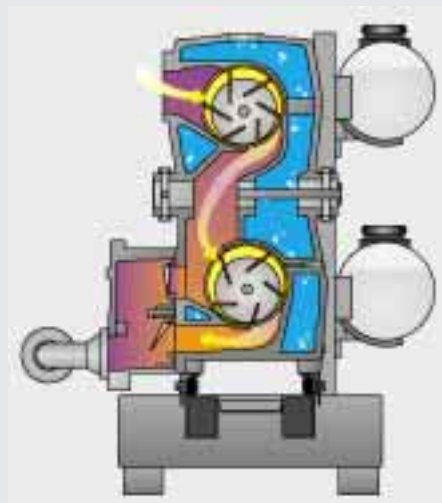

Technical Data

Huckepack HO Model		0429	0433	0437	0441	0445
Nominal pumping speed	ACFM	100	155	265	390	625
Free air displacement	CFM	113	176	282	444	700
End vacuum	Torr	0.5	0.5	0.5	0.5	0.5
Motor size for 3 phase	HP	10	15	20	25	40
Sound rating	dBA	79	79	80	81	85
Standard sealant capacity	Qts	12	12	25	25	25
Sealant usage rate (min-max 24 hrs)	Qts	4-6.3	4.8-6.3	5.6-11.2	7-11.2	11.5
Cooling water consumption	GPM	0.5	0.75	0.9	1.6	2.1

Seco Vacuum Pumps

Description

The Busch Seco vacuum pumps are oil-less pumps which require no routine maintenance due to sealed-for-life ball bearings and self-lubricating, dry carbon composite vanes. The vanes are self-adjusting for constant high operating efficiency and a longer service life than other designs available today. The Seco pumps have a vacuum range from 0 to 27" Hg, and are ideal for such applications as material handling, sampling, hold-down, testing, packaging, molding, medical, laboratory, and the printing industry.



Seco SV 1025 C

Seco Operating Principle

Seco vacuum pumps operate according to the proven rotary vane principle without using additional sealing fluids for lubrication. These vacuum pumps compress almost without pulsation and are completely oil-free. An efficient fan guarantees good heat removal from motor and pump.

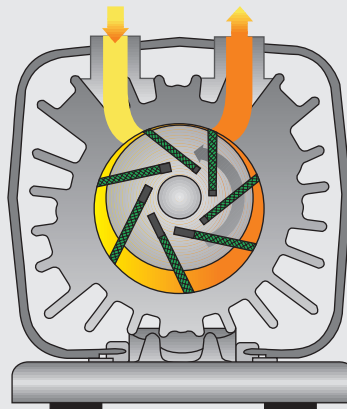

Busch Advantages

- Easy to install
- 100% oil-free air
- Quiet operation
- Extra long-life composite vanes
- Low maintenance
- Discharge muffler
- Available in single phase or three phase, depending on size

Technical Data

Miniseco SV Model		1004	1006		
Nominal pumping speed	ACFM	3.0	4.2		
End vacuum	"Hg	25.5	25.5		
Motor size	kW	0.2	0.3		
Seco SV Model		1010	1016	1025	1040
Nominal pumping speed	ACFM	7	11.2	17.5	28
End vacuum	"Hg	25.5	25.5	26.38	26.38
Motor size	kW	0.37	0.55	0.90	1.25
Seco SV Model		1063	1080	1100	1140
Nominal pumping speed	ACFM	44	56	66	88
End vacuum	"Hg	27	27	27	27
Motor size	kW	2.2	3	4	5.5



Central Vacuum Systems

Description

Centrally located Busch vacuum systems reduce both maintenance and energy costs compared to multiple single pumps. Busch offers a wide range of standard vacuum systems to meet specific requirements for a variety of applications in many different industries.



R 5 Expandable Pentaplex Vacuum System

Industrial Vacuum Systems

Description

Industrial vacuum systems are available in a variety of vertical and horizontal configurations and are designed for easy expansion using mechanical and electrical expansion modules.



Mechanical Expansion Module



Components of the Electrical Expansion Module



R 5 Tank Mounted Duplex Vacuum System



Mink Stack Mounted Triplex Vacuum System



R 5 Vertical Tank Mounted Simplex Vacuum System



R 5 Mobile Simplex Vacuum System



R 5 Expandable Duplex Vacuum System



R 5 Tank Mounted Simplex Vacuum System

Laboratory Vacuum Systems

Description

Designed specifically for laboratories, these Busch vacuum systems are equipped with a manual or automatic purge assembly to remove condensable vapors from the pump prior to shutdown. They also feature special seal

materials; corrosion resistant components in the exhaust box; and an exhaust flange adapter to permit remote exhausting of gases. Busch laboratory systems are available in many configurations.



Mink Tank Mounted Duplex Laboratory Vacuum System



R 5 Expandable Duplex Laboratory Vacuum System

Medical Vacuum Systems

Description

Busch medical vacuum systems are engineered and manufactured to provide hospitals and surgical centers with high quality, reliable, and low maintenance equipment. Busch has a

widespread installed base of vacuum systems that is one of the largest in the industry. Systems are available in many configurations, and all systems meet or exceed NFPA 99C guidelines.



Mink Stack Mounted Quadruplex Vacuum System



R 5 Tank Mounted Duplex Vacuum System



R 5 Base Mounted Triplex Vacuum System



Mink Space Saver Duplex Vacuum System

Busch Advantages

- Lower overall energy use than individual point-of-use pumps
- Heat and noise removed from point-of-use location
- Easy access for servicing
- Automatic alternation between pumps for even wear
- Easy modular expansion expansion
- Backup pump eliminates downtime
- Low maintenance
- Manufactured in the United States
- Proven reliable pump designs
- Low cost of ownership
- ISO 9001-2000 Registered Company
- Dedicated engineering support



Custom Designed Vacuum Systems

Description

Busch custom designs vacuum systems to meet specific performance requirements. From the simplest single pump system to complex computer controlled systems, Busch provides complete vacuum systems that include instrumentation, controls, monitors, computer hardware and software, and

other special equipment. Busch's highly experienced engineering staff will work with you to determine the pump system configuration that will meet your specific requirements.



COBRA Vacuum System

Dry screw vacuum pump system with control panel, knock-out pot, and auto purge for a filter/dryer application.



COBRA Vacuum System

Dry screw vacuum system with a vacuum receiver control panel, operator interface and particulate filters for central lab applications.



COBRA Vacuum System

COBRA AC system designed for a chemical processing application and includes a variable speed motor; nitrogen stage cooling and seal purge; automatic and manual nitrogen purge package and automatic flush package.



COBRA Vacuum System

Dry screw vacuum system with variable frequency drive for process control, knock-out pot, vacuum booster and control panel for specialty chemical production.



COBRA Multi-Pump Vacuum System

Dry screw vacuum pump system with control panel, operator interface, muffler, knock-out pot, auto purge, and solvent recovery system for independent laboratory applications.



COBRA Vacuum System

Includes rotary lobe booster, annunciator panel, knock-out pot and after-condenser for a pharmaceutical application.



Huckepack HO Mark 4 Vacuum System

Includes knock-out pot, auto purge, annunciator panel, exhaust mist eliminator and a recirculating cooling system, designed for a pharmaceutical application.



COBRA Vacuum System

Dry screw vacuum system with knock-out pot, check valve and stainless steel muffler is ideal for pharmaceutical and chemical applications.

Other Vacuum Equipment

Description

Busch offers a wide range of vacuum components and equipment to ensure that your vacuum pump or system provides optimum performance and reliability to meet your process requirements.



Panda Rotary Lobe Vacuum Booster

Busch Panda boosters are air-cooled, positive displacement rotary lobe blowers intended for use in conjunction with a backing pump. Vertical flow prevents material build-up within the booster and a bypass valve permits continuous operation from atmospheric pressure.



Samos SB Regenerative Blower

Busch Samos SB regenerative blowers are designed for either pressure or vacuum. Both single and two stage models operate over a wide range of flow and differential pressures.



Dolphin Liquid Ring Vacuum Pump

The Busch Dolphin is used in a wide range of industries and is able to pump gases, vapors and handle entrained liquids. The Dolphin is single stage, compact, and direct driven.



Phenix Dry Waste Collection System

The Busch Phenix dry waste collection system collects scrap pieces with vacuum created by a three stage centrifugal blower. The unique design, with its suction in the center, allows the removable collection canister to fill completely. It is air cooled, oil-less, and has a stainless steel housing and transparent cover.

Busch Advantages

- Proven reliable designs
- Low cost of ownership
- ISO 9001-2000 registered company
- Dedicated engineering support
- Nationwide service network
- Operation and maintenance training
- Extensive parts inventory



Vacuum Accessories and Maintenance Items

Description

In addition to the accessories shown on this page, Busch has many other accessories designed to enhance the performance of your vacuum pump. These include: annunciator panels,

auto purge, instrumentation panels, condensers, exhaust mist eliminators, inlet scrubbers, and process control valves, just to mention a few.



Vacuum Inlet Filters

Two stage filters to remove solids as small as 0.3 microns.



Knock-out Pots

Prevents entrained liquids from entering vacuum pumps.



Gauges

Bourdon-tube, chemical resistant, capsule types, and digital.



Busch Vacuum Pump Lubricants

Special lubricants for longer pump life.



Bag-Type Vacuum Inlet Filters

High volume self-cleaning bag filters to remove solids in the 5 and 10 micron range.



Maintenance Kits, Exhaust and Oil Filters

For optimum pump performance.



Busch Cleartrap

Liquid separator for pump protection.

Busch Factory Service

Description

Busch offers a valuable combination of total service support and engineering expertise to ensure maximum uptime and low cost of ownership throughout the life of your pump. Strategically located regional factory service

facilities maintain a large parts inventory and are staffed with factory trained service technicians, who are ready to assist you with all your equipment needs.



Busch Service Centers

We offer quick product turnarounds and prompt deliveries.



Busch Overhaul Services

Busch provides complete overhaul kits to restore your Busch pump to its original high efficiency.



Busch Service Technicians

Our strategically regional service facilities are staffed with factory trained service technicians who are ready to assist you with all your vacuum equipment needs.



Busch Factory Service Centers are located in:

Virginia Beach, Virginia
S. Plainfield, New Jersey
Glendale Heights, Illinois
Houston, Texas
Cerritos, California
Bayamon, Puerto Rico

Busch Advantages

- Quick product turnaround
- Exchange programs
- Factory trained service technicians
- Preventative maintenance training
- On-site repair and start up assistance
- 24 hour emergency phone line
- Extended pump warranty when maintained with genuine Busch parts
- Comprehensive repair reports
- Service contracts
- Control system diagnostics
- Engineering support
- ISO 9001-2000 registered company





Busch - all over the world in industry

Busch LLC
516 Viking Drive
Virginia Beach, VA 23452
Phone (757) 463-7800
FAX (757) 463-7407

www.buschusa.com

1-800-USA-PUMP

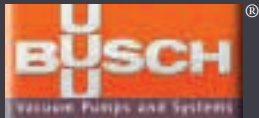

ISO 9001-2000 Registered Company



DN 100

Visit our website to find out about the Busch company, our vacuum products, factory service, and technical data.

www.buschusa.com